

## 37 The Wind Process Cards

We will now introduce the 40 “Process” cards in the Senet Tarot deck. We will begin with the suit of Wind. We can call it the suit of Air, but the process that it is best known for is that of the winds that blow in the atmosphere. Wind arises because of temperature differences in the air. Warm air rises, and cold air sinks. The change of air temperature is due to the influence of sunlight hitting the atmosphere. Also the sun’s warmth affects land masses and water masses in different ways, because they absorb heat differently. The temperature of the earth’s surface warmed by sunlight further affects the air above it. The earth’s rotation creates currents of air that tend to flow in prevailing directions.

We see from this that wind is a cosmic phenomenon caused by the introduction of energy into the earth’s environment. Most of that energy comes from the sun and the earth’s rotational momentum, with small amounts coming from elsewhere.

Wind is a symbol of the Cosmic Will that follows the natural laws of material phenomena in the universe. Each individual organism also has a will to some degree by which it can govern its own activities. By tuning to the Cosmic Will it is possible for an individual with limited strength to magnify his local strength and achieve performance that would otherwise seem impossible. One of the earliest discoveries related to this principle was finding that, if you spread a piece of cloth or even animal skin into the wind, it can pick up the flow of the wind and turn it into a force that can be used to accomplish work. Builders of boats that can float on rivers, lakes, and oceans, soon learned that rowing a boat is a lot of work, especially if it is against a current. By spreading out a piece of cloth for a sail, the energy of the wind can be captured and used to propel a boat. All you need to do is trim the sail at the right angle to catch the wind, and then use a steering oar to keep the boat headed in your chosen direction.

The will is a tool of consciousness with which you can decide which direction you want to go. Finding how to get there may involve additional decisions, but taking action is the first step. The Egyptians used birds as common symbols of the soul and spiritual qualities because of their ability to fly high in “heaven”, so the feather was a natural symbol for truth.

The suit of wind is the executive suit. Only those who are willing to make a decision and then take action to fulfill that decision belong to the executive class. Such people naturally become leaders, because they are willing to take a risk and take the responsibility for what happens as a result of their decisions and actions. Most people are too conservative to risk standing out ahead of the herd and asserting that they have the “right” way to get to a particular goal. They accept that they may make a mistake or be wrong, but that risk is better than doing nothing if there is a need or desire to get to a “better place”. Therefore, the true executive class tends to be a bit lonely. Sometimes executives get together and share their secrets of success. The other suits are adjuncts to decision making and performance that can help to ensure success in life and benefits for the community.

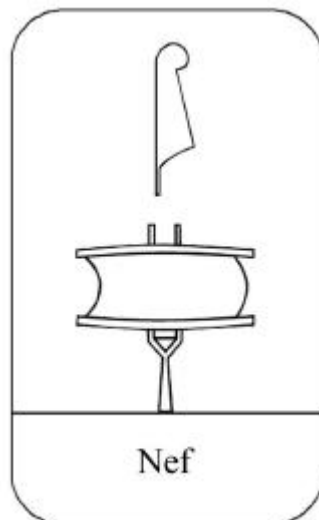

The “Ace” (1) of Winds is the Cosmic Will. In nature it is the wind “Nef” that blows over land and water. In a person it is his breath that flows in and out of the body in a cycle. The wind moves in cycles, and if we know the cycles we can use it for many purposes. The science of deliberate breathing is a profound and ancient discipline capable of harnessing life energy in remarkable ways. A sail on a frame is the symbol for the invisible wind. It is the tool for catching the wind even though it is not the wind itself.



In the illustration Ani and his wife wade in the waters of the Nile (representing the flow of life) and hold little sails so they can navigate through life in the direction they prefer. They ritually also drink the life-giving waters of the Nile.

The sail by itself will not take you anywhere. More is needed.

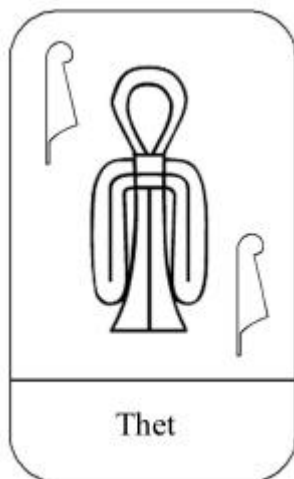

The 2 of winds is the “Theta”, the Knot of Isis. The story is that, after Set “killed” her husband, Osiris, Isis still did not have an heir to replace Osiris as pharaoh (Baba was not interested in being a ruler and Anubis was the son of Osiris by Nephthys), so she swore she would not take another mate until Osiris returned from the “dead”. The knot is a strip of cloth a woman used in ancient times to wipe the blood of her menstrual flow. For Isis this was the symbol of her deliberate decision to await the return of Osiris and a sign of her determined action to say “no” to Set or any other who approached her as a potential mate.

The ironic outcome of this decision is that Osiris indeed was brought back to life by Thoth and Baba. Being an archetype of nature, he could not really die anyway. He just went through a transformation and became the god of plants and agriculture. He was called “Nep”, the

grain god. However, he had lost the ability to procreate as a husband, so Ra stepped in and (presumably with the OK from Osiris who at this point identified with Ra) became the proxy father of Horus, the son who became the heir to Osiris. This was OK, because Osiris was not dead, and furthermore had realized that his true identity was Ra-Horus the elder. All plants grow from the energy of the sun. They are expressions of the Rays of Ra. So Isis realized that her true husband was Ra, and that Osiris was only Ra's emanation to demonstrate the truth about life and death -- that "death" is an illusion caused by a blockage in consciousness to the eternal flow of love and light. We thus learn that Isis and Ra have a very deep and timeless relationship, which is why Isis is often raised to the status of Mut Hathor, the Cosmic Empress and Mother.

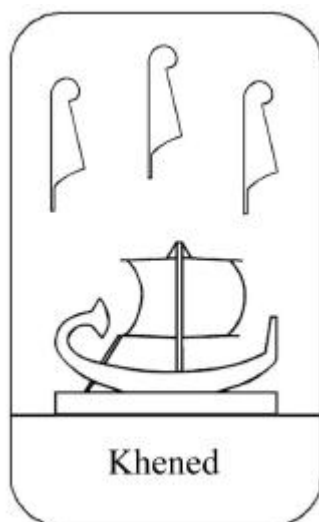

Once we have decided where we are headed, we can fasten our sail to a boat and move toward our goal. Once the sail is properly trimmed, we only need to hold the steering tiller steady and we can even head upstream against the natural flow of a river. The ability to sail up the Nile was critical to maintaining the unity of North and South Egypt. It had to be easy to go in both directions. The word "Khened" is related to the word for a chief or leader and alludes to the leadership expressed when such a technology is available to maintain unity even despite natural flows of energy in other directions. The three tools are the sail, the boat, and the steering tiller (plus, of course, a skilled pilot and crew).

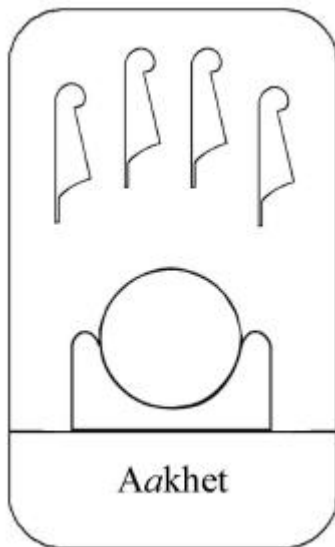

There are particular times of day when the winds begin to settle down. These times are dawn and dusk. Such a time was called by the Egyptians “Aakhet”. At these times the sun is on the horizon providing some light but no more heat. So the winds tend to settle down. The boundaries between day and night set the definition of a day and a night. The ability to manage boundaries and the gaps between them is a major executive skill. A country with no defined boundaries does not have a well-defined existence. So pharaohs often put markers to determine the legal boundaries of the country. Nature does not have fixed boundaries, but there are regions where the scenery shifts enough that we can speak of a boundary. For example a sea shore, or the course of a river, or a mountain range can form a natural boundary. Consciousness also has boundaries where we shift from waking to sleeping, or from sleeping into dreaming. There is a strange boundary where consciousness in the form of a thought slips away and there is only awareness with no defined boundary. The ancient Egyptians used the sun on the horizon as the symbol for this boundary-less boundary. The word for a boat in Egypt had a word play on another word meaning meditation. So meditation was a way of navigating in consciousness to a place where the limiting boundaries of thought slip away and nature’s truly undefined property becomes clear. Meditation was a major Egyptian executive skill for managing the ever-shifting boundaries of national affairs.

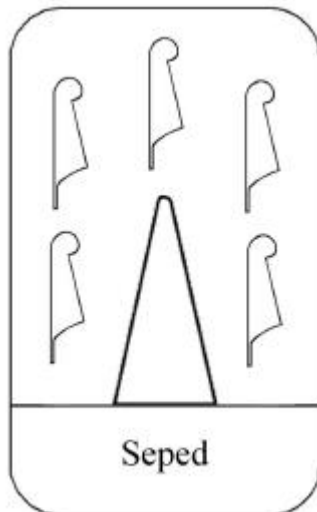

"Seped" is the abstract image of a thorn. It means preparedness. Life can present many difficulties, and a pharaoh had to be ready for any situation that could bring suffering to his people. There is a story that Ra was proud of his creations and used to go for walks in his world to admire them. Isis wondered why these wonderful creations left so many people mired in suffering. Why was Ra in charge and not herself? She knew that true compassion would not create suffering for people. So she took a thorn and put some magic poison on it. She used some of Ra's saliva (he was old and tended to dribble) to make a little mud serpent and put the thorn on it as a tooth. Ra stepped on it and experienced excruciating pain. Of course, Isis was one of his creations and she just let him have a taste of his own medicine. Nobody could cure Ra's pain until Isis came forward and offered an antidote, but the condition was that Ra would have to tell her his "true name". Ra gave her all his grand titles, but they did not count. Isis needed to know the secret name Ra's parents hid inside him when he was born to protect him from the magic of shamans (like Isis). Finally there was no other recourse and Ra told her his secret name, which is "Amen", and means "hidden". As soon as he told her the name, he disappeared from his seat in the Solar Boat and it became "empty". The pain and suffering also disappeared. This is the secret of the Egyptian meditation. You must go beyond all the labels you think are important to you and reach the hidden reality that is who you really are. You are a creator who defines attributes and not a creation that has attributes, so you have no attributes. All attributes become hidden and invisible in the undefined reality at the source of meditation.

An additional aspect of the triangular thorn is that it is the sign of the star Sirius. This star very reliably would appear above the horizon in a

heliacal rising just when the Nile would begin to rise in its annual flood, bringing relief from summer drought and a return to abundance and the new agricultural year. Ironically this Thorn of Isis brought relief from suffering to all of Egypt every year.

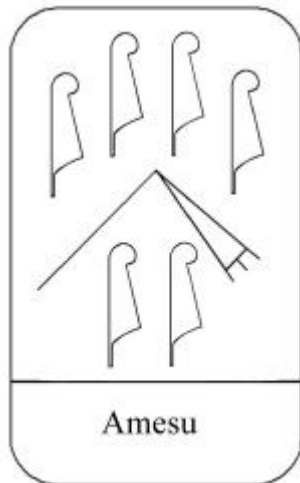

The “Amesu” or “Ag” flail was a tool used by the farmer at harvest time to separate the grain from the chaff. He would beat it with the flail to loosen the chaff and then winnow it so the loosened chaff would blow away in the breeze. As Egypt’s Farmer-in-Chief the pharaoh carried the flail as a symbol of his executive responsibility to carry the agricultural year from planting to harvest after the annual Nile flood prepared the fields. This ensured that the granaries would be full and the people would have bread throughout the rest of the year. Osiris, as the god of grain and the archetypal pharaoh, carried this symbolic tool. An executive executes his responsibilities to the fullest extent he is able.

Once while traveling in Tibet I saw a woman wielding a flail on a pile of grain in her yard. I was surprised at how large it was, because the ritual tool carried by pharaoh does not look very useful on the farm, but is just a symbolic power accessory.

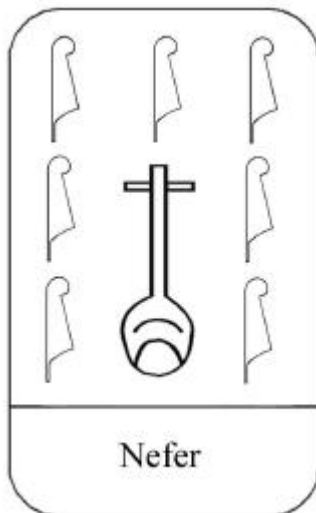

"Nefer" means beautiful, but the true beauty meant here is "integrity". When an executive or leader becomes very busy, it is easy for the situation to get complicated. A leader's eligibility as a leader depends on his integrity with regard to the mission he undertakes. If he starts to compromise and engage in forms of deceit or dishonesty, then the mission loses its "beauty" as something meaningful for what it proclaims and begins to become a sham. The leader becomes no different than the deluded "Devil" opponent that he opposes or the problem he aims to correct. Nefer comes from a pure heart. The glyph is a pictograph of a musical instrument.

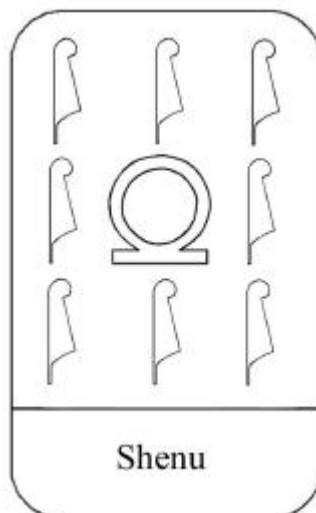

"Shenu" is a cyclical process that also makes progress. This is a key management principle. When an operation is large and complex there must be rules that regulate the flow of the operation. There is a proper sequence. When the process flows smoothly it can iterate over and over to create an abundant effect. This is the principle of mass production. First the product or service must be perfected and tested in the market. The production process



then must be fully debugged. Once something of value has been set up in this way, there can be a plentiful supply to fulfill all demands. The repetition of a useful cycle is the key to abundance. Traditionally the vulture goddess Mut delivers the Shenu loop.

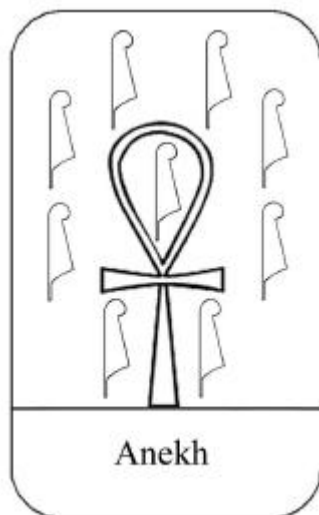

”Anekh” means “life”. The accessory is a little mirror for confirming the presence of life breath in a person. Life is a mysterious process filled with challenges and opportunities. A person unable to make decisions is as if dead. Making a decision stimulates the life breath. The secret of life is to find the “mission” that is right for you and decide on it. Then you can unfold your creative potential to its fullest and enjoy a life without struggle, because every step along the way and every experience becomes part of the Life Mission. Nothing is ever wasted. Doubts and worries disappear because life is lived in the certainty of who I am, why I am here, and what I am doing. The key to life is aligning your breath of life with the Cosmic Will. Then the flow of the universe toward its final intention becomes effortless. The individual becomes part of the Vast Cosmic Game that is played in harmony for the ultimate benefit of all, because the universe is a unified reality and every part has a role in that unity.

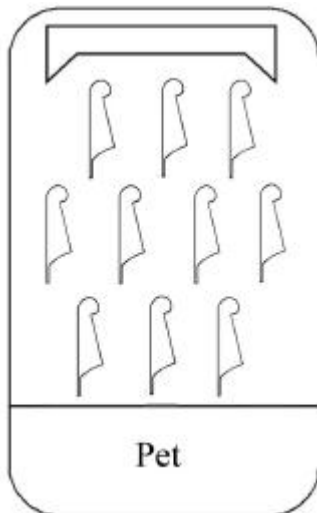

"Pet" is Heaven. All wind occurs in the realm of Heaven (what we usually call the realm of the sky.) The goal of any good executive is to create Heaven on Earth. The challenge is that the appearance of Heaven is a subjective phenomenon that depends on a person's point of view. Indoctrination and brainwashing is not the way to Heaven. The perception has to be real and honest. The Cosmic Will is invincible and will always get its way. The individual will that is not aligned with the Cosmic Will may experience conflict and results other than those intended by the Cosmic Will. The challenge is how to comfortably align the individual will and the Cosmic Will. The Key of Life supplies the hint that an individual who finds a life mission that is aligned with the Cosmic Will naturally and effortlessly begins to enjoy the comfortable ride to Heaven, since that is the goal of evolution for the benefit of all. Nobody prefers the universe to end up as a chaotic trash heap. An important point to remember is that the universe operates under the principle of least action, so the Key to Heaven is to relax and reduce the effort one makes to get things "right". Then Heaven will naturally appear on the horizon.

## 37 Study Questions

- \* What is the symbolic meaning of the Wind Process?
- \* Why do we have Wind on our planet?
- \* What is Will?
- \* What is the difference between individual will and Cosmic Will?

- \* What is the value of an individual tuning his will to Cosmic Will?
- \* Why is the suit of Wind especially related to the performance of an executive?
- \* Why is the executive role often rather lonely?
- \* Wind is invisible, so what tool do we use to symbolize it graphically?
- \* What is the Egyptian symbol for the spiritual aspect of the Wind?
- \* Why do executives often become leaders in society?
- \* What is the role of "Wind" in human physiology?
- \* What combination of tools are needed to effectively harness the Wind?
- \* What does the Knot of Isis mean, and how is it a symbol of executive performance?
- \* How did Wind become an effective tool for keeping Egypt unified?
- \* What is the usefulness of Windlessness?
- \* Study the story of Ra and Isis for insight into the suit of Wind.
- \* What is the symbolic role of the pharaoh's flail power accessory?
- \* How does a musical instrument relate to the wind and to executive performance?
- \* Why does Mut deliver the Shenu Loop?
- \* What does the "Anekh" symbol have to do with "Wind"?
- \* What is Heaven on Earth?